



TECHNICAL BULLETIN

1-800-237-0022

Stock No. H85 – HOLLAND SEVERE DUTY SLIDER BRACKET, TRADITIONAL (non-ILS)
PART NO. 53-10412-002

CONCEPT:

This slider bracket is designed for mounting load cells under SAF-Holland severe-duty FW70 fifth wheel top plates. This bracket can be used on traditional style (non-ILS) severe-duty SAF-Holland slide tracks.

APPLICATION:

A system consists of two DSB VULCAN fifth wheel load cells (Stock No. L75) and a traditional style (non-ILS) severe duty slide bracket supplied with mounting hardware (Stock No. H85).

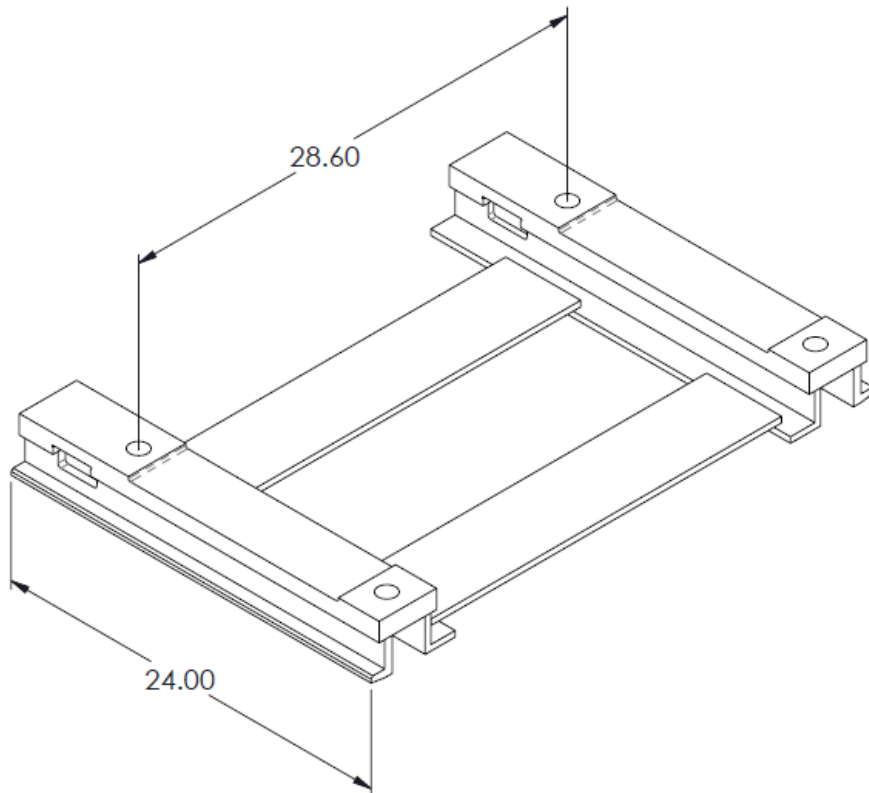



TECHNICAL BULLETIN

1-800-237-0022

SPECIFICATIONS:

- **CAPACITY:** 70,000 lb vertical load
150,000 lb draw bar pull*
- **SLIDER BRACKET MATERIAL:** ASTM A514 (bearing plate) and ASTM A36 steel.
- **PLATING:** Vulcan slider brackets are painted for increased rust protection.

*Per SAF-Holland requirements FW70 top plate capacity is reduced when used in a sliding application.

Note: Plungers and release mechanism are not sold with slider bracket assembly and must be obtained from a SAF-Holland dealer. For retrofits, the existing release mechanism can be used. Stress-Tek, Inc. bracket assembly is designed to fit the plunger style introduced in May, 1982. All earlier models must convert to XA-0372A plunger style.

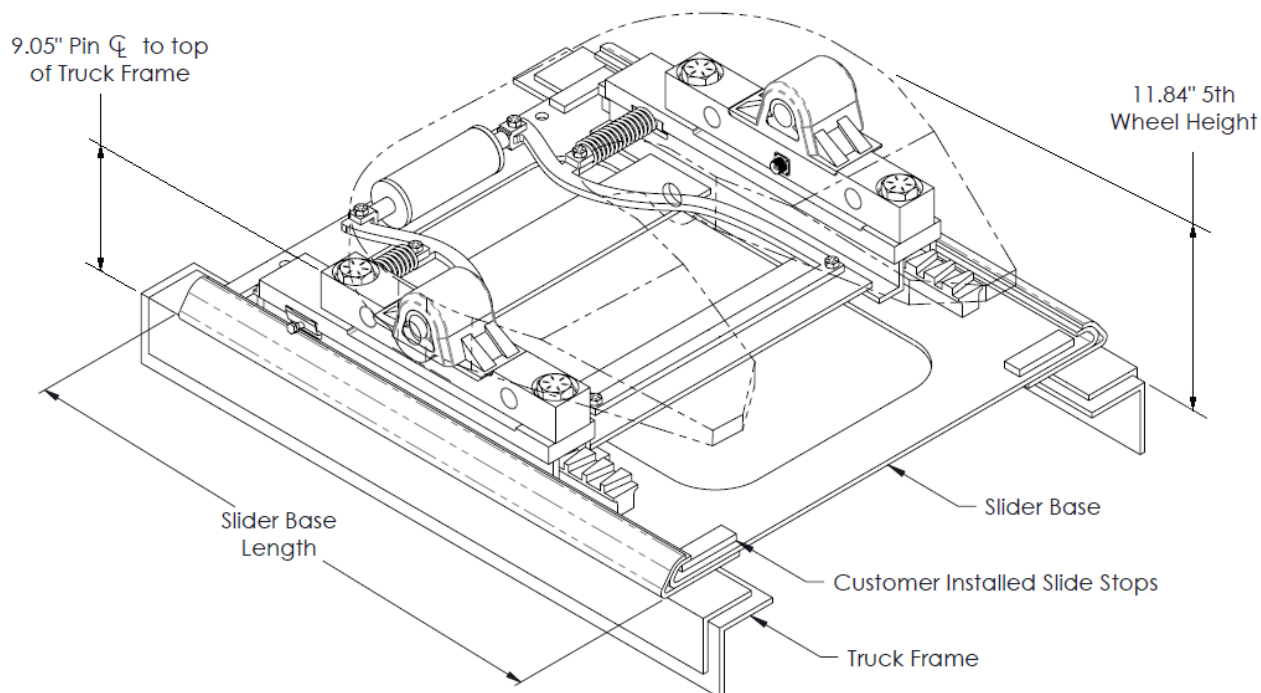



TECHNICAL BULLETIN

1-800-237-0022

INSTALLATION:

Step 1 - REMOVING EXISTING SLIDING FIFTH WHEEL

Carefully remove the slide stops at the back end of the slide tracks. Disengage lock pins and remove fifth wheel. Extend the plungers and slide the existing bracket assembly off the ends of the tracks. If the release mechanism is air operated, check the hose length to determine if it needs to be removed before or after sliding the bracket assembly off the tracks. See FIG.152-A.

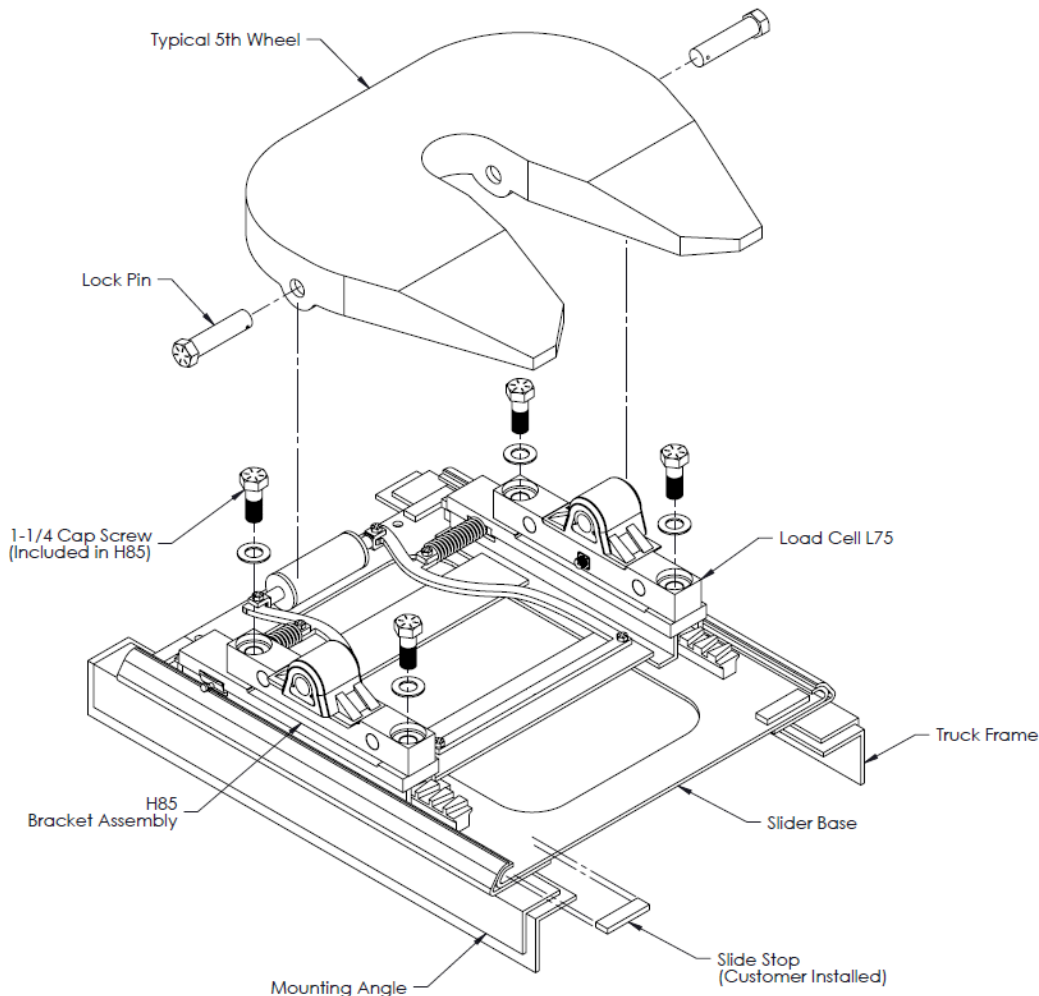

FIG. 152-A



TECHNICAL BULLETIN

1-800-237-0022

Step 2 - REMOVE RELEASE MECHANISM

To remove the plungers, the springs must be compressed and held to remove the pins that retain the plungers to the release mechanism. SAF-Holland has a tool available (Part No. TF-TLN-2500) designed exclusively for removing and installing springs, retainers and pins for the slide release mechanism.

Step 3 - INSTALLING BRACKET/LOAD CELL ASSEMBLY

For new tractors, a slide base plate of the desired length must be installed. Location and installation procedures must follow guidelines recommended by SAF-Holland.

Slide Vulcan bracket onto base plate. Use "Never-Seez" or equivalent thread lubricant when installing all mounting cap screws. **DO NOT use the "Never Seez" on the load cell connectors.** Assemble load cells onto slider plate and tighten bolts finger tight. Lubricate the lock pins before reinstalling. Assemble fifth wheel top plate to load cells and torque the 1-1/4" diameter mounting cap screws to 1450-1780 lb-ft.

Locate rear slide stops under the curled edge of the slide base plate and approximately 1/4" to 1/2" from the rear edge of the plate as shown in FIG. 152-B. Any paint, grease or other debris must be removed from weld area prior to welding. Clamp slide stops in place and weld. Size welds per SAF-Holland recommendations. Use of a low hydrogen welding process following American Welding Society (AWS) codes and specifications is recommended. Take precautions to ensure the tractor electrical system is not damaged during welding.

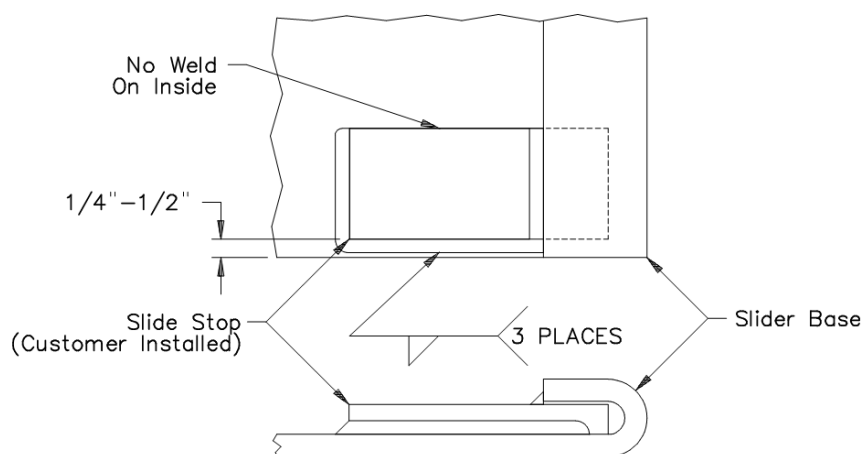

FIG. 152-B



TECHNICAL BULLETIN

1-800-237-0022

Step 4 - WIRING AND OPERATION

Secure Vulcoder to tractor and route the black cables to the load cells and the orange cable to the meter in the cab. Route the cables so they will not be damaged by road debris and allow for travel in the sliding bracket assembly. **Note: Do not** grease or lubricate inside the Vulcan load cell connector or Vulcoder connector. These components are highly sensitive to foreign substances and inaccurate readings will occur if these components are contaminated. **Your manufacturer's warranty does not cover the failure of Vulcan components due to contamination (use of grease or other conductive substance) in either of these component connectors.** For additional electronic installation notes and operation procedures, see the *"Vulcan Operator And Maintenance Manual"*.

Step 5 - INSPECTION AND LUBRICATION

Make sure the plungers on the sliding bracket engage properly into the rack. Proper adjustment of the sliding bracket locking plungers must be performed at installation and maintained at regular intervals by use of the adjusting bolts provided on both sides. Adjustment is required for proper operation, load transfer, and distribution. Follow procedures specified by SAF-Holland.

Apply lubricant to the bearing surface on the load cells through the grease fitting on the side of the fifth wheel plate. The plate must be lifted up slightly to relieve weight while applying lubricant. Apply diesel oil or other lubricant on the rack and slide path of the bracket assembly.

Load cell mounting cap screws must be checked periodically for proper torque.

	1-1/4"
SAE J429 - Grade 8	1450-1780 lb-ft