



SERVICE BULLETIN

1-800-237-0022

SUBJECT: INSTALLATION OF CONNECTOR GUARD

EFFECTIVITY: FORK SCALES

PROBLEM: Fork Scale connector and cable are being damaged.

SOLUTION: Add connector guard to protect fork connector and cable.

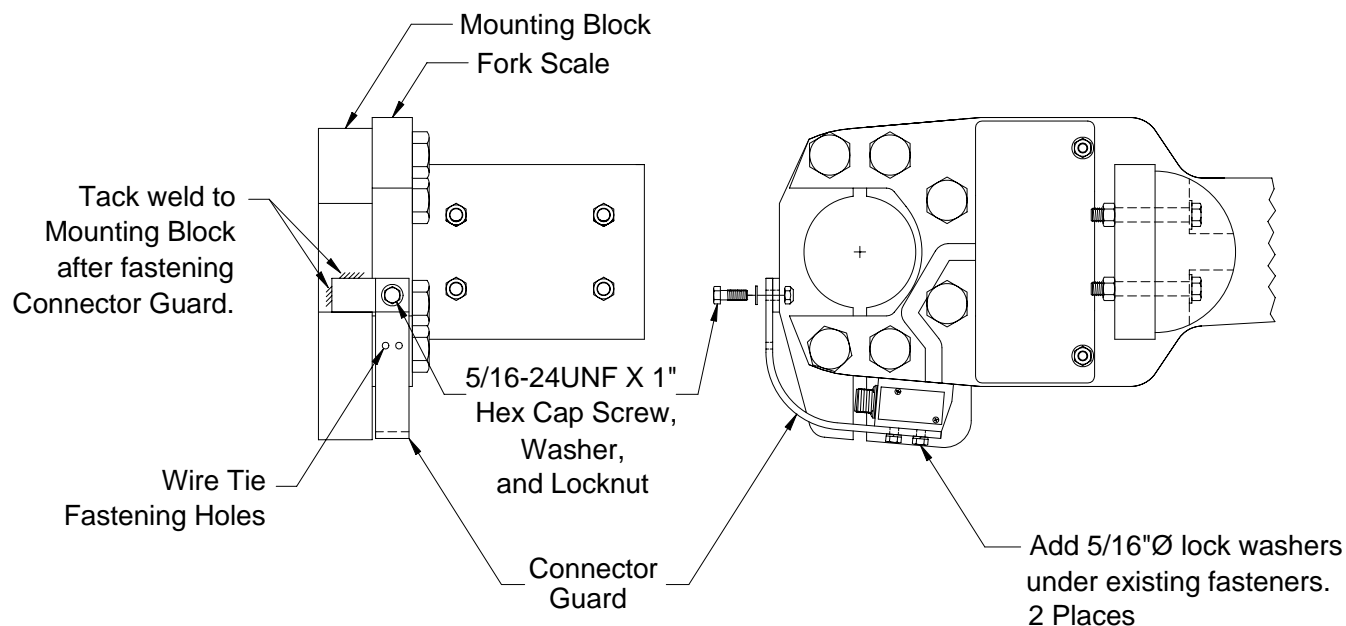

NOTE: After installation, paint parts using a rust preventative paint.