



**VULCAN WEIGH-IN-MOTION WITH LIFT CONTROL
FORK KIT INSTALLATION INSTRUCTIONS**

WEIGH-IN-MOTION WITH LIFT CONTROL KIT INSTALLATION MANUAL

Table of Contents:

1.0	PROXIMITY SWITCH KIT INSTALLATION	3
1.1	PROXIMITY SWITCH INSTALLATION.....	3
2.0	HYDRAULIC FLOW CONTROL VALVE INSTALLATION AND CONFIGURATION	8
3.0	ELECTRICAL SCHEMATICS / DIAGRAMS	10
3.1	WEIGH-IN-MOTION WITH LIFT CONTROL SYSTEM ELECTRICAL SCHEMATIC	10
3.2	METER WIRE CONNECTION DIAGRAM	11
3.3	HYDRAULIC VALVE WIRE CONNECTION DIAGRAM	12
3.4	CONNECTION TO TRUCK BATTERY	13
4.0	METER SET UP AND SYSTEM TEST.....	14
4.1	OPERATION CHECK OF PROXIMITY SWITCH AND HYDRAULIC VALVE	14
4.2	START UP DISPLAY METER.....	15
4.3	ERASING THE METER AND VULCODER.....	17
4.4	METER SET UP FOR WEIGH-IN-MOTION.....	19
4.5	VERIFY FORK OPERATION.....	20
5.0	CENTERLINE LOCATING TOOL	21

1.0 PROXIMITY SWITCH KIT INSTALLATION:

1.1 PROXIMITY SWITCH INSTALLATION:

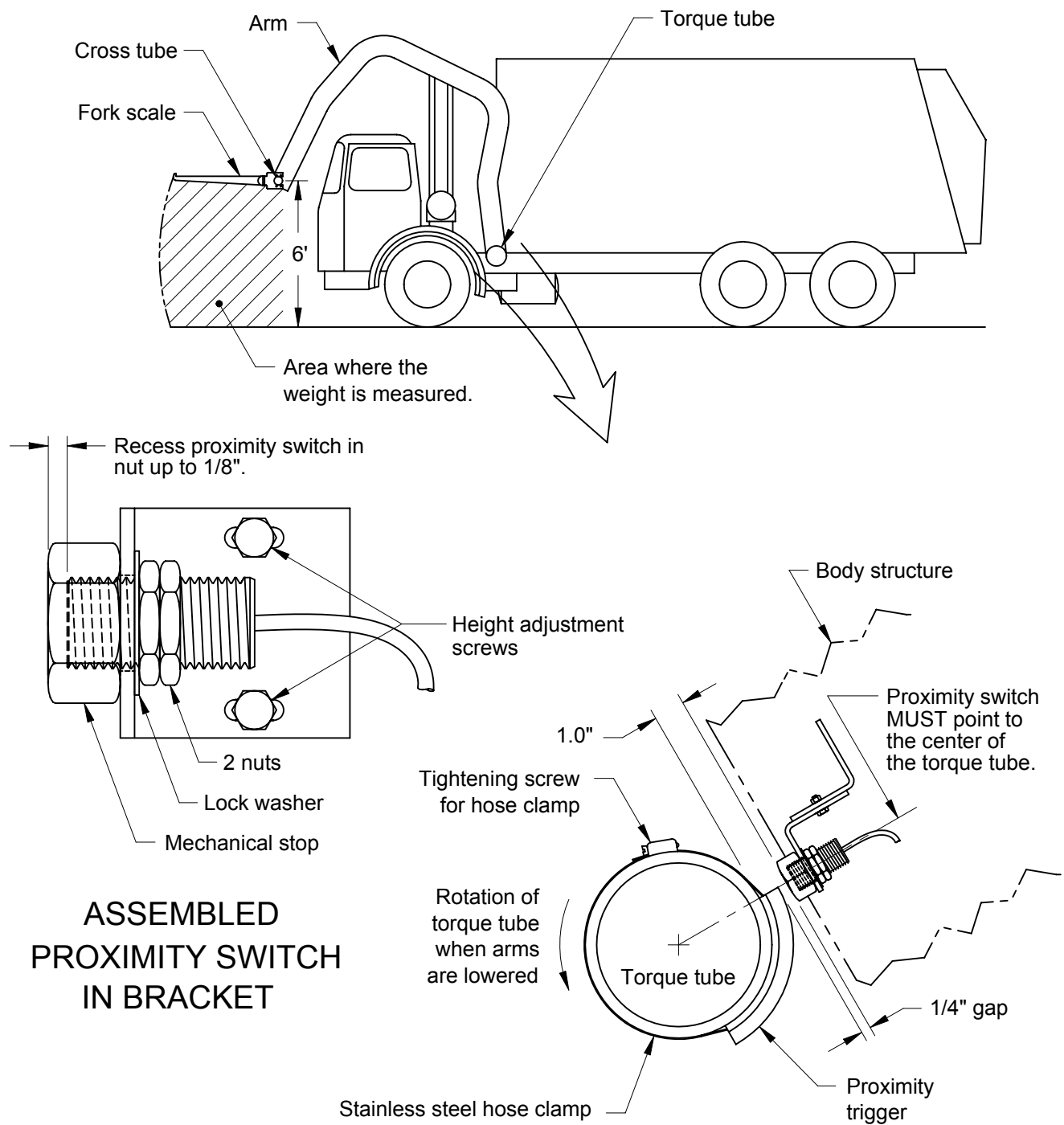

Figure 1-A

1. Raise the cross tube until it is six feet above the ground. Locate a position on the truck body structure, near the torque tube, where the supplied bracket can be installed. Proximity switch must be installed on truck body, not on truck chassis. The base of the nut must be 1" from the surface of the torque tube.

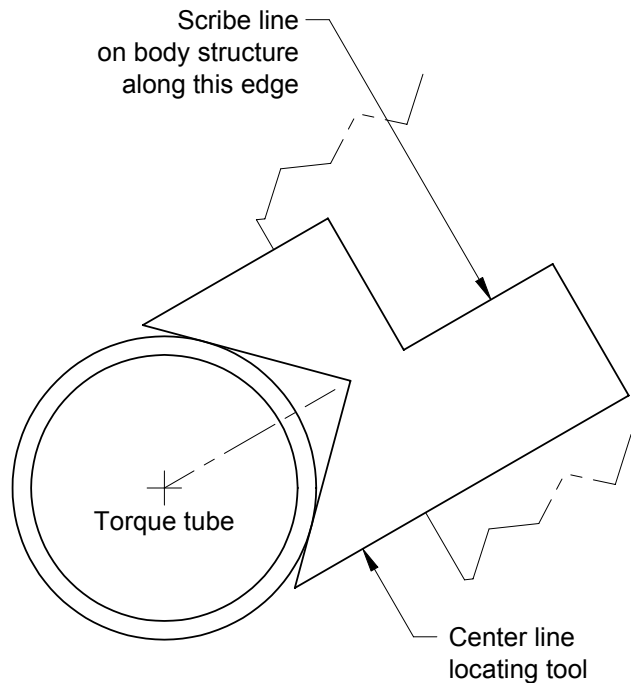

Figure 1-B

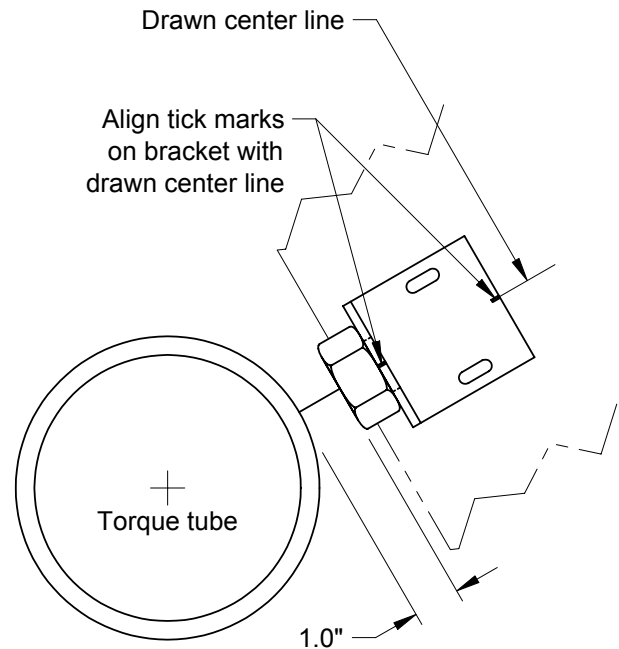

Figure 1-C

2. Cut the "Center Line Locating Tool" pattern from the back page of these installation instructions. Place the "Center Line Locating Tool" on the torque tube and mark a line on the body structure where the bracket will be installed, see Figure 1-B.
3. Use the tick marks on the angle bracket to align it with the vertical line drawn on the truck structure. This aligns the center of the bracket with the center of the torque tube. The base of the nut must be 1" from the surface of the torque tube. The bracket can be cut down or additional bracketry can be welded to it so it fits properly in the desired area, see Figure 1-C.

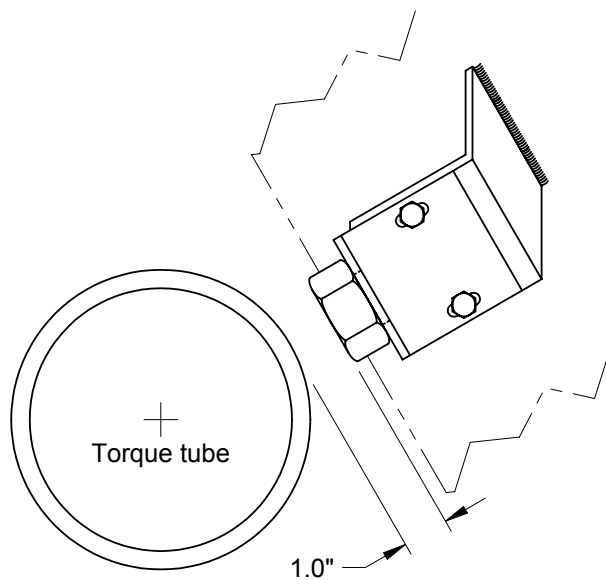

Figure 1-D

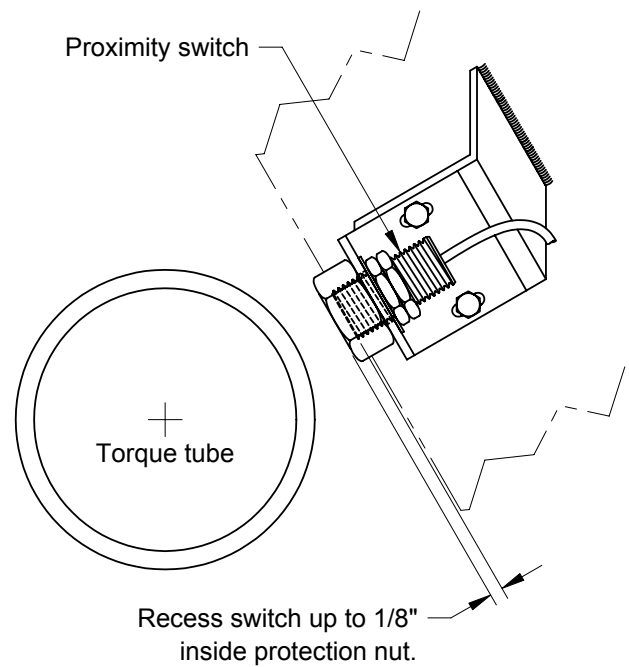

Figure 1-E

4. Weld bracket to the truck structure, and set 1" nut height off torque tube, see Figure 1-D.
5. Install the proximity switch in the bracket nut. Tighten in place so that the sensor is recessed in the nut up to 1/8", see Figure 1-E.

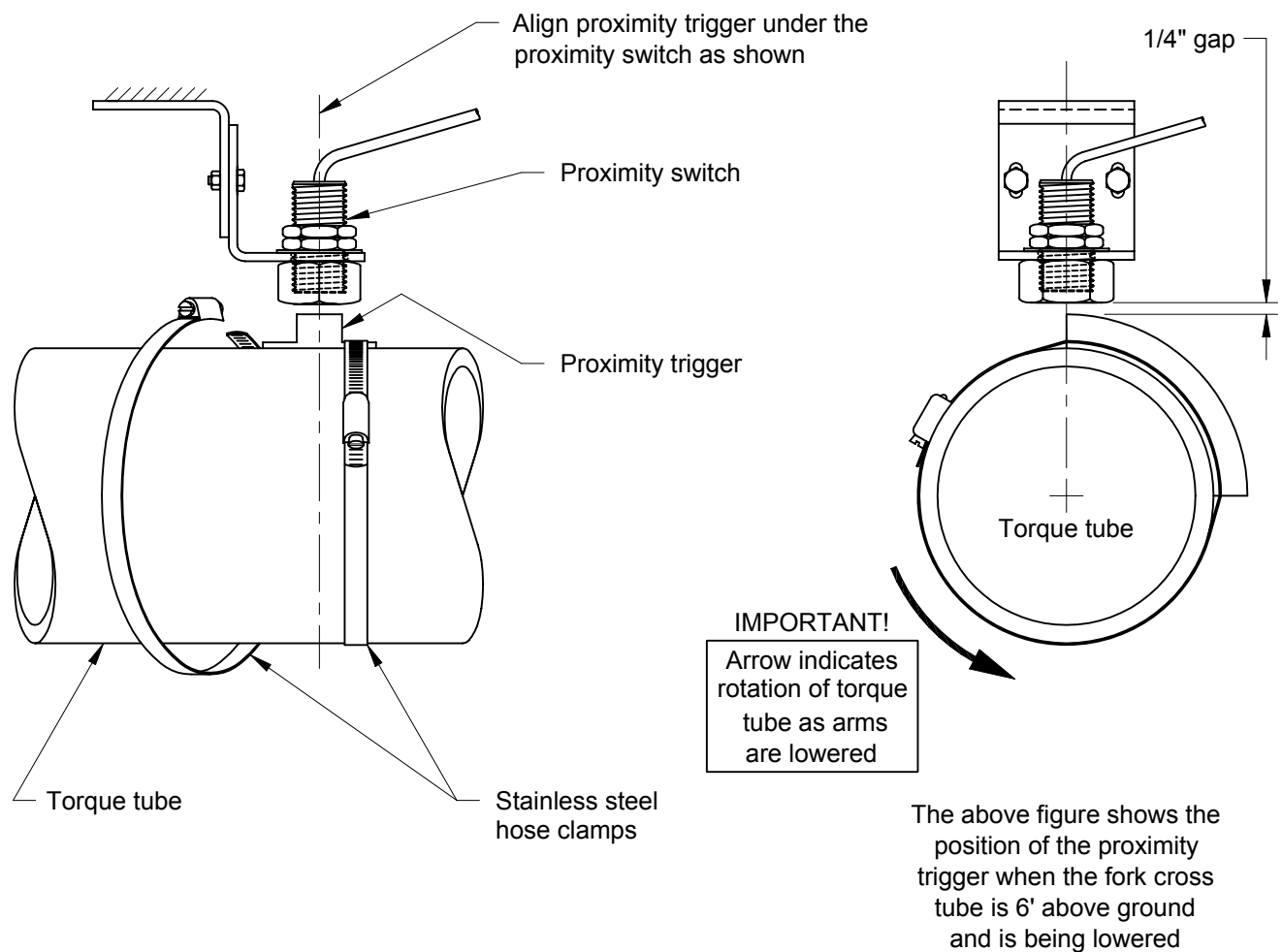

Figure 1-F

6. The proximity trigger will be mounted directly below the proximity switch on the torque tube. Clean off grease and debris from the torque tube in this area. Use the hose clamps to fasten the proximity trigger to the torque tube. Verify that the cross tube is six feet off the ground before final alignment. Align the trigger with the proximity switch and set up the final installed distances as shown in Figure 1-F.

7. As the arms are raised and lowered, the gap between the proximity sensor and the proximity trigger must remain 1/4". If the gap is greater than 1/4", the sensor may not trigger properly.
8. When the position is finalized, tighten the 2, 1/4-20 fasteners and tack weld the 2 mounting plates together so they will not slip.
9. Mount the junction box in a protected location on the truck body structure.
10. Route and secure the proximity switch wires to the junction box. For trucks that tip to eject and tip for service route and secure the orange and grey cables through the body rear hinge point to the junction box.
11. The junction box comes with the relay already wired to the proper terminals. Wire the orange and grey cables to the junction box as shown in Figure 2-A.

2.0 HYDRAULIC FLOW CONTROL VALVE INSTALLATION AND CONFIGURATION:

1. Install the Vulcan control valve between the main valve manifold and the "T" connection as shown. The valve must be installed where it can affect both hydraulic cylinders.

It does not matter whether the arm cylinders are single acting or double acting. The valve will work for both types. On double acting cylinders, the valve must be installed in the return line when the cylinder is extending.

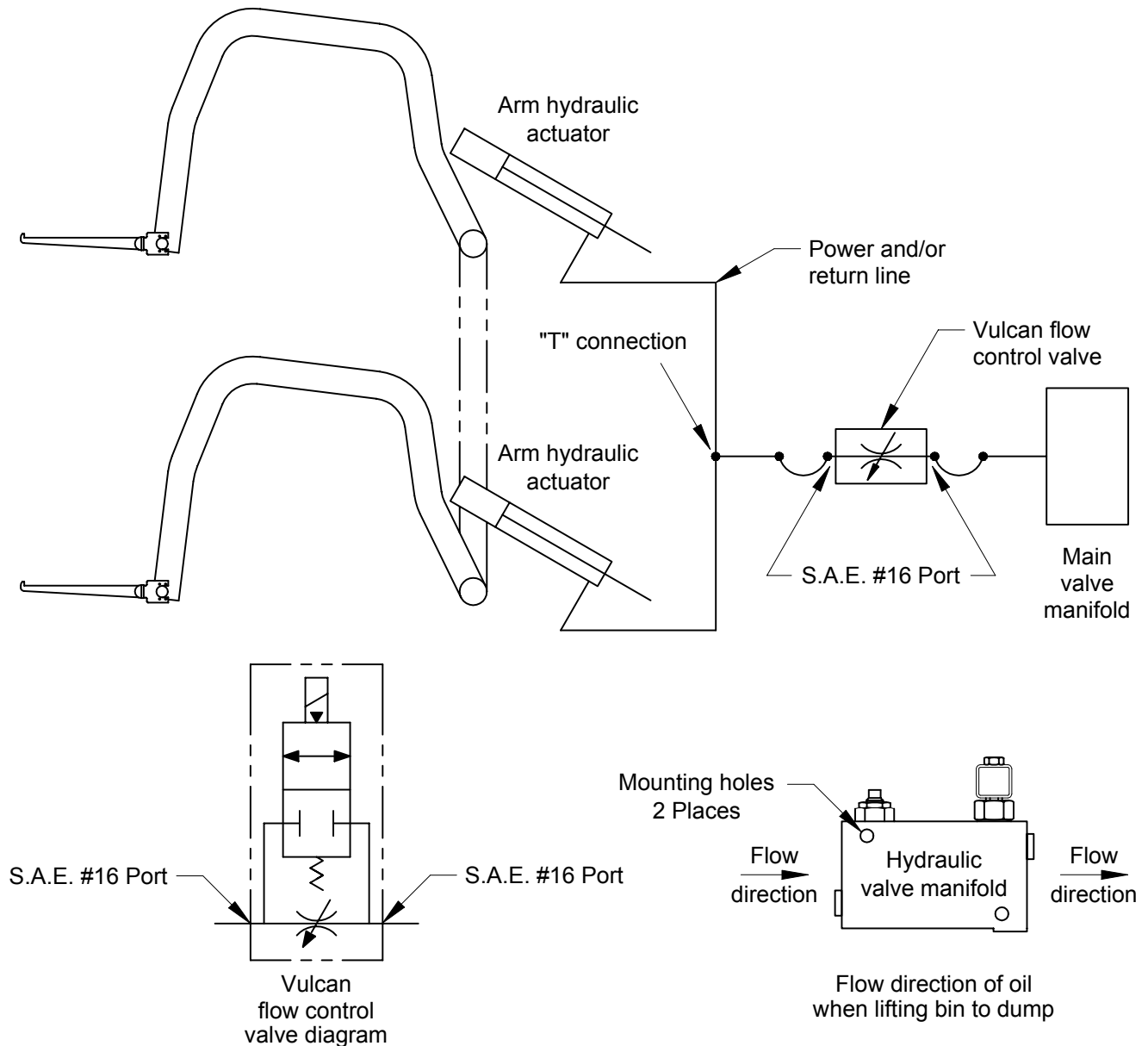

Figure 2-A

Use the two holes in the valve manifold to mount the unit to the truck body structure. It may be helpful to bolt the valve to a larger piece of steel angle or tube, then bolt or weld the angle or tube to the truck body structure.

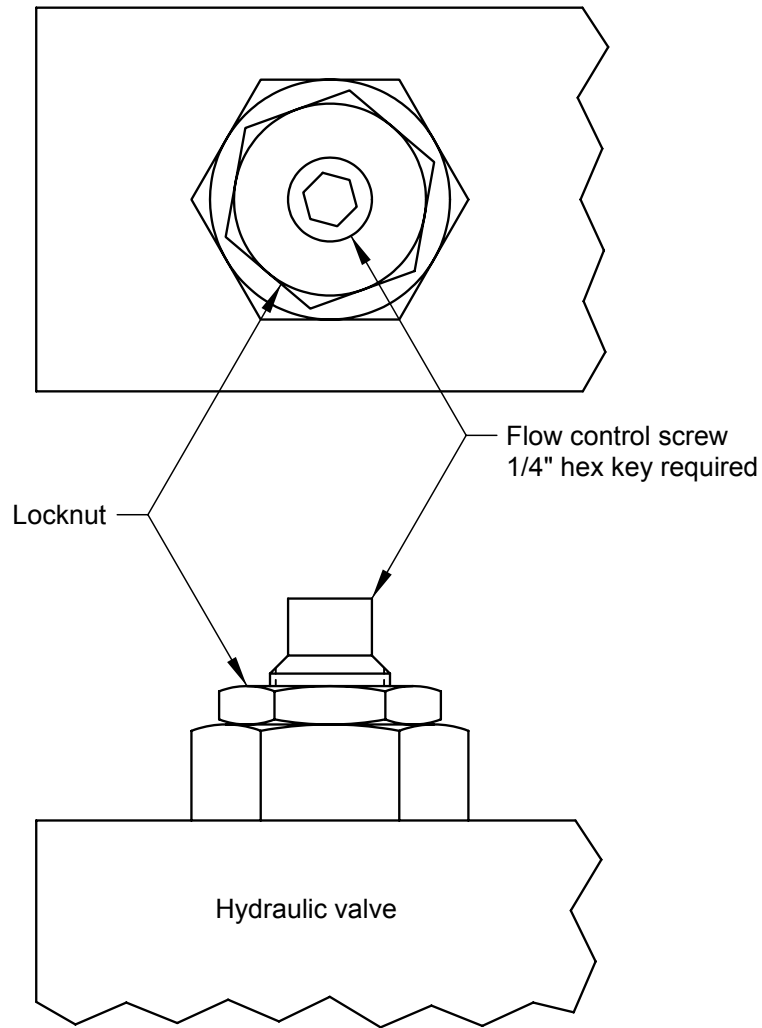

Figure 2-B

Factory recommended setting for Weigh-In-Motion: Flow control screw open 1-3/4 turns counterclockwise.

Procedure for adjusting flow control screw to factory recommended setting:

- Step 1: Loosen the flow control screw locknut.
- Step 2: Turn the flow control screw clockwise until tight. This fully closes the valve.
- Step 3: Turn the flow control screw counterclockwise 1-3/4 turns and tighten the locknut. The flow control valve is now at the recommended setting of open 1-3/4 turns.

3.0 ELECTRICAL SCHEMATICS / DIAGRAMS

3.1 WEIGH-IN-MOTION WITH LIFT CONTROL SYSTEM ELECTRICAL SCHEMATIC:

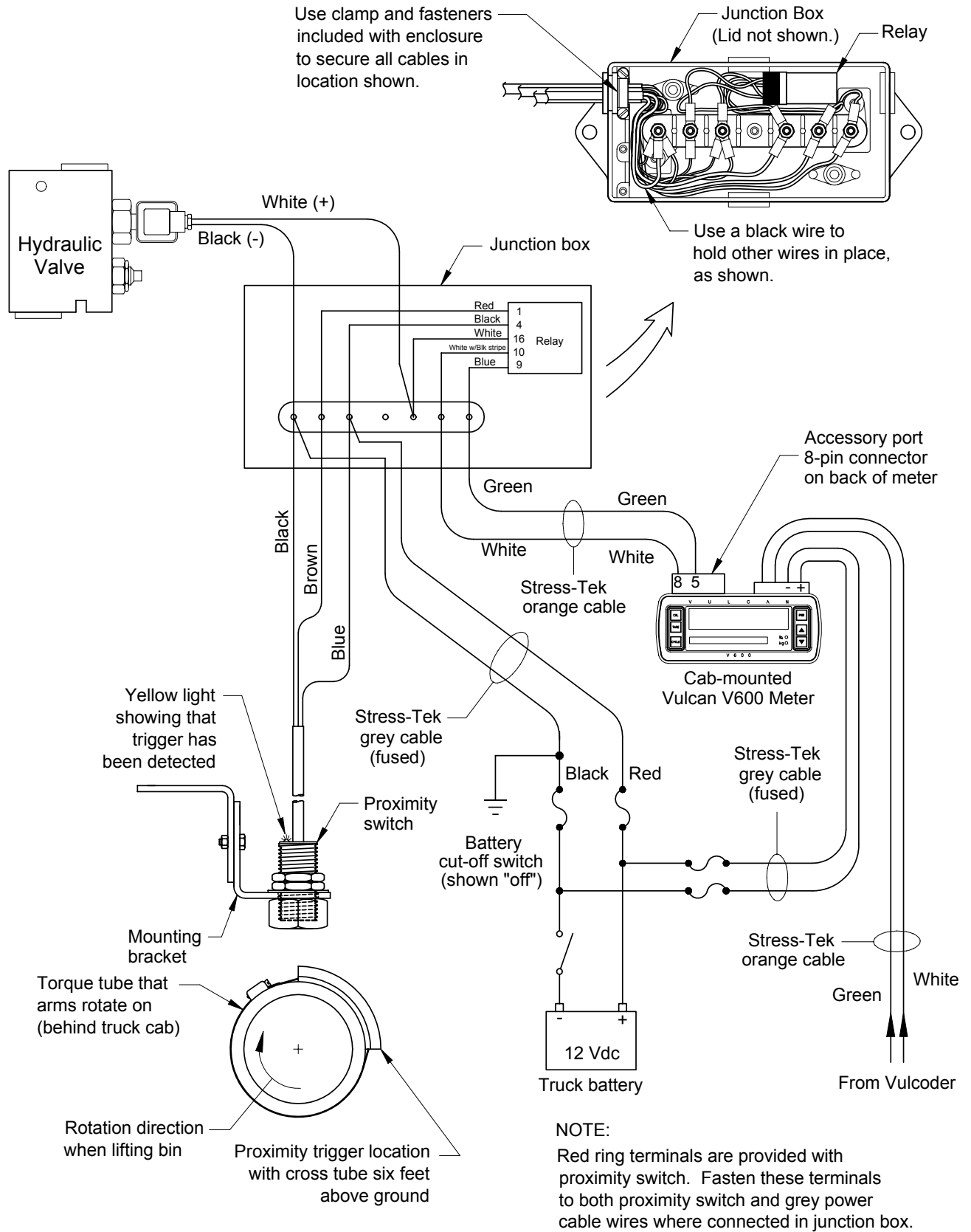

Figure 3-A

3.2 METER WIRE CONNECTION DIAGRAM:

Unplug the Accessory terminal block from the back of the meter, strip the wires, and connect the Control Button wires to the terminal block as shown below.

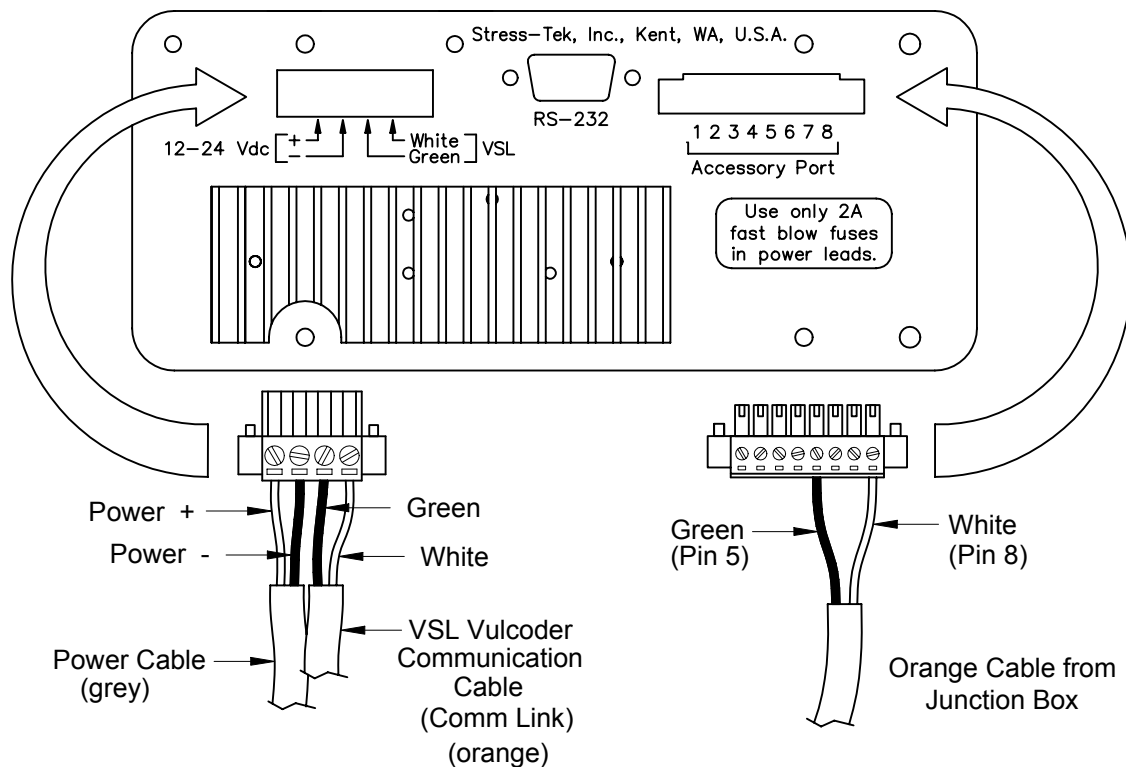

Figure 3-B

Route the grey power cable from the truck battery to the meter in the cab. Route through the cab hinge point. The fused end must be at the battery end of cable.

In the truck cab, cut the VSL Vulcorder cable and meter power cable from the j-box to ideal lengths. Unplug the terminal blocks from the back of the meter, strip the wires, and connect the wires to the terminal block (refer to Figure 3-B). Be careful that stray wires **DO NOT** contact adjacent terminals. **Do not** plug the terminal block into the meter at this time.

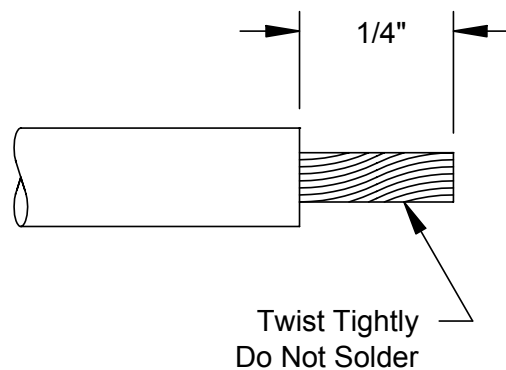

Figure 3-C

3.3 HYDRAULIC VALVE WIRE CONNECTION DIAGRAM:

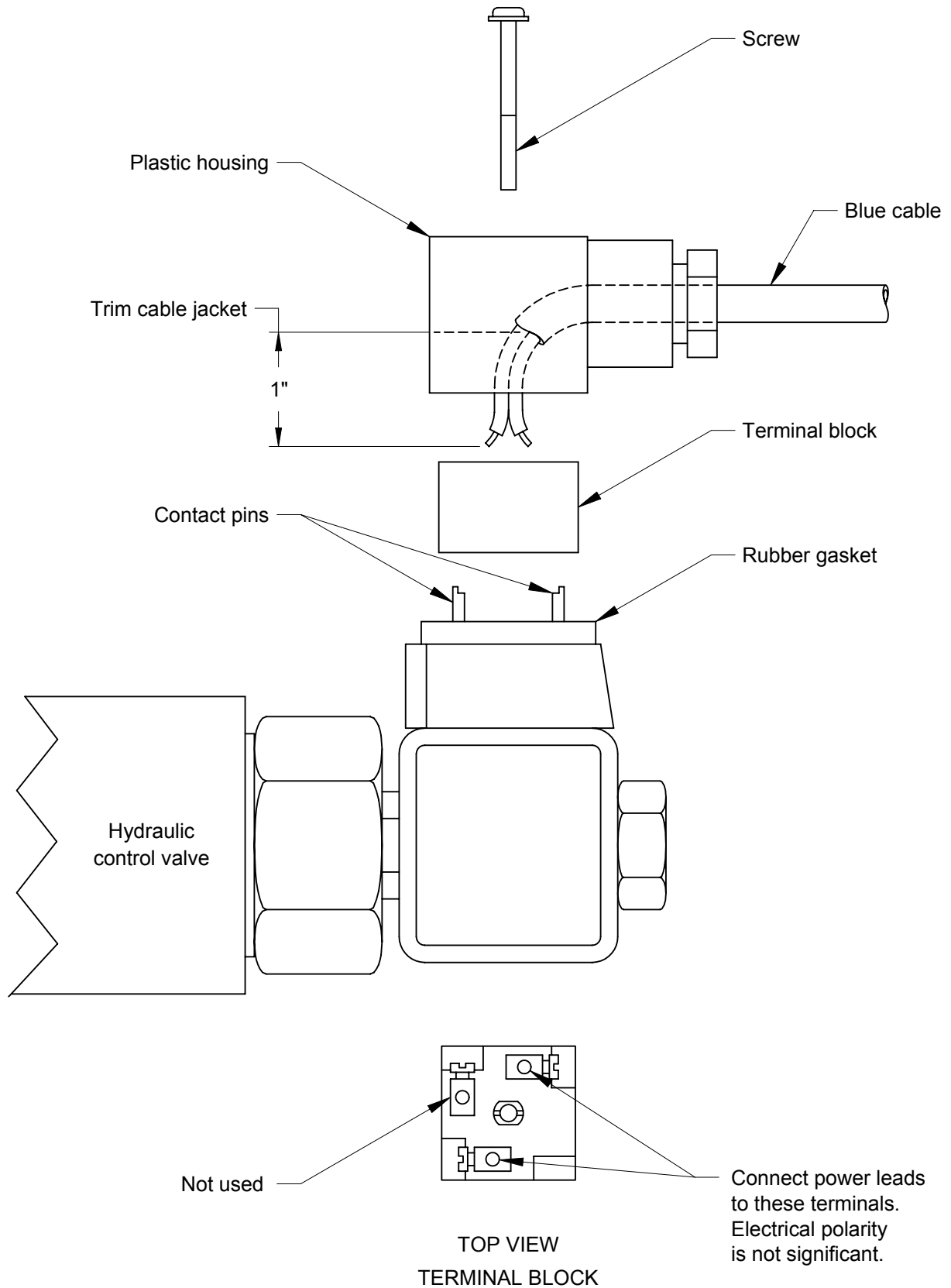

Figure 3-D

3.4 CONNECTION TO TRUCK BATTERY:

Disassemble the positive fuse holder, (red wire). Apply grease to the positive connector at the battery post to inhibit corrosion. Connect fused power leads directly to battery posts for best operation. Crimp ringed terminals to the power leads. Power must be connected directly to battery. Maximum power is 29 Vdc. **Note:** Vulcan V600 meters are configured to be used in **12 Vdc** system using **2 amp** fast blow fuses in both power and negative leads. **Do not** connect the power cable to a power source activated by the key switch.

Remember: Turn meter off while making any wire connections.

WARNING: If installing the meter in a vehicle with a **positive ground** electrical system, the meter chassis, mounting bracket, and mounting fasteners **MUST** be electrically isolated from the vehicle chassis.

4.0 METER SET UP AND SYSTEM TEST:

4.1 OPERATIONAL CHECK OF PROXIMITY SWITCH AND HYDRAULIC VALVE

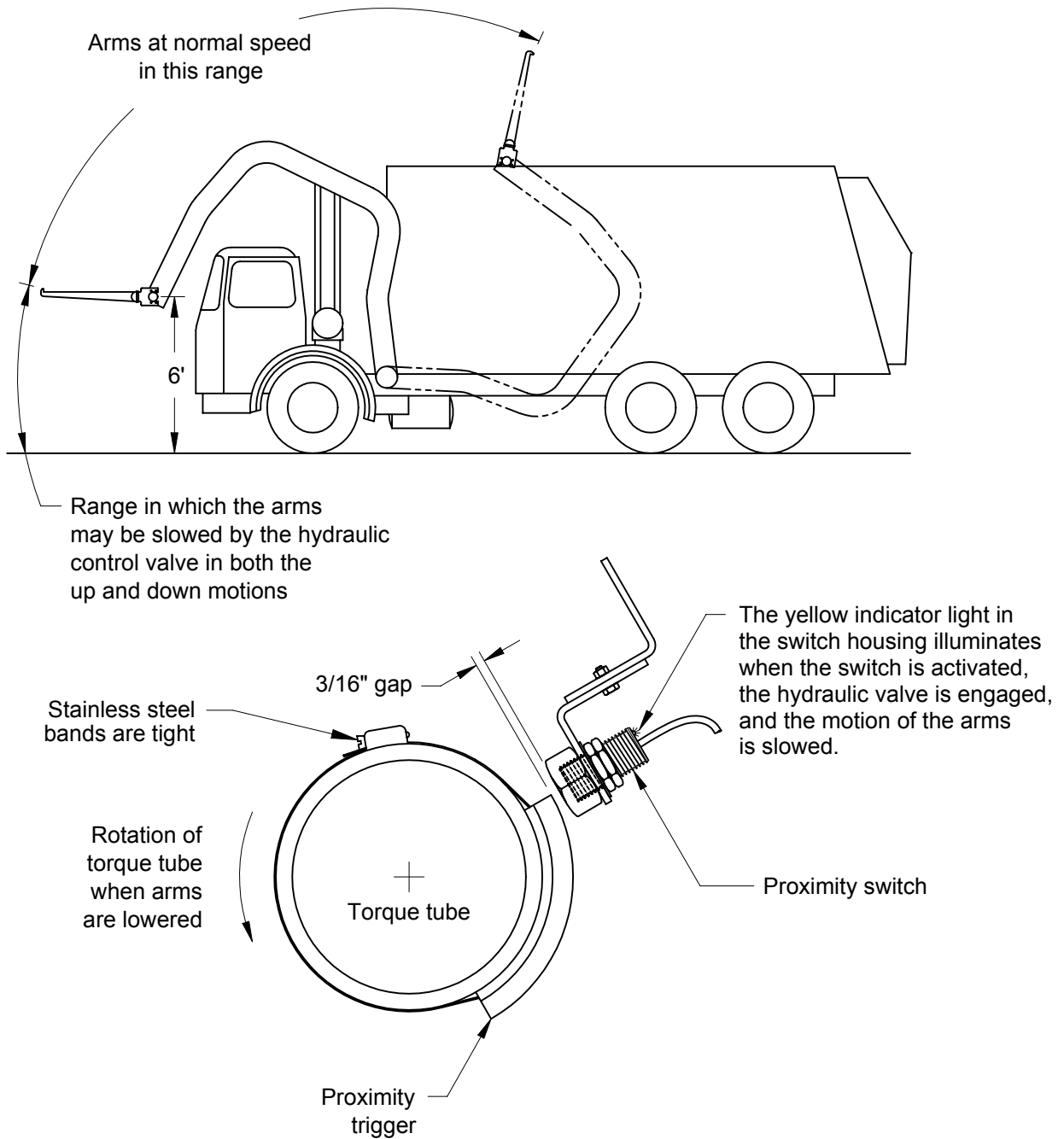

Figure 4-A

4.2 START UP DISPLAY METER

Note: If there are any problems with the following quick system tests, contact Vulcan Customer Service, see last page for details.

1. Start the truck.

Bring the arms down and put the forks in a level position.

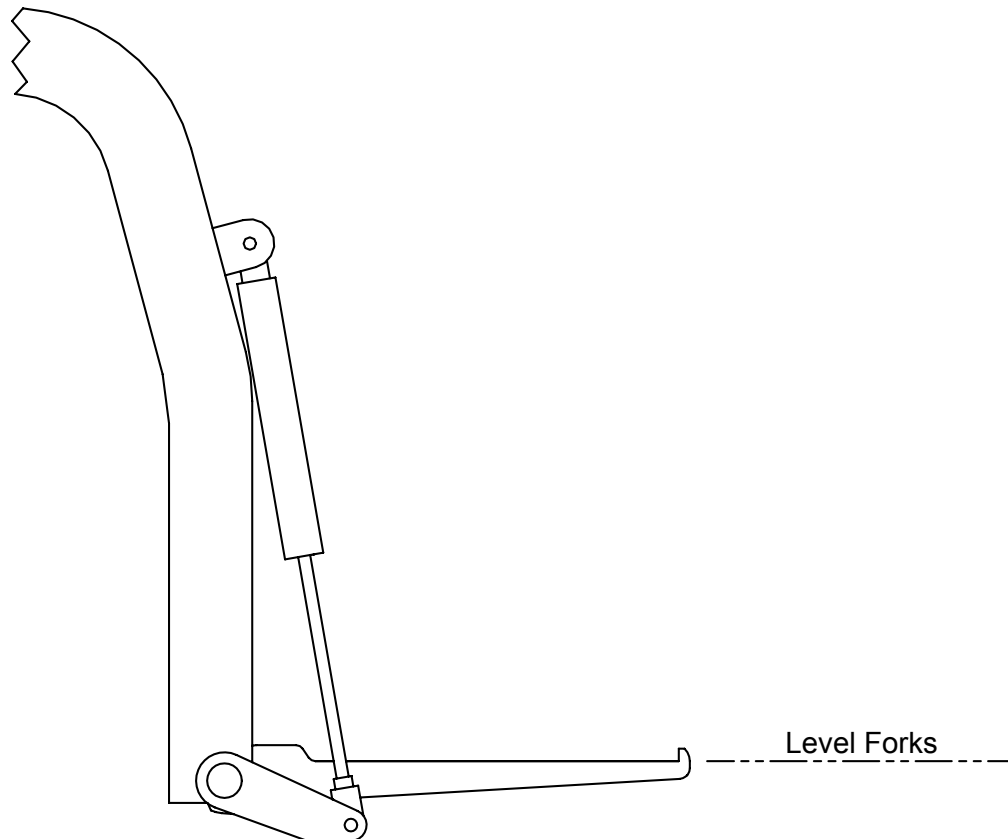

Figure 4-B

- Turn the meter on and go through start up sequence.



Press the **PWR / MENU** button for less than 2 seconds.

After the meter has completed its startup routine, the meter will display **ENTER ROUTE NUM.**



ENTER ROUTE NUM



Press the **ENTER** button to enter the Route Number.

The display will ask if you wish to reset the customer number.



RESET CUST? [Yes]



Press the **ENTER** button to reset the customer number.



NEXT CUST # 1

4.3 ERASING THE METER AND VULCODER



Press the **PWR / MENU** button to enter the Program Menu.



Press the **CYCLE** button until **SEQUENCE CHANLS** is displayed.



SEQUENCE CHANLS



Press the **ENTER** button to select the **SEQUENCE CHANLS** Menu option.



DISPLAY SEQUENCE



Press the **ENTER** button to enter the **DISPLAY SEQUENCE** Menu option. The meter will display the truck Vulcoder in a few seconds and will display it as a rear <r> designator.



Press and hold the **ENTER** button for a one or two seconds to erase the Vulcoder. The meter will display <->. This shows that the Vulcoder has been erased.



Press and hold the **ENTER** button again to erase the meter. The meter will display all 8's on the upper display and **---Wait---** on the lower display.



Press and hold the **PWR / MENU** button until the meter powers off. Once the power is off, press the **PWR / MENU** button again to power the meter back up.

Again, go through the start up sequence.



Press the **PWR / MENU** button for less than 2 seconds.

After the meter has completed its startup routine, the meter will display **ENTER ROUTE NUM.**



ENTER ROUTE NUM



Press the **ENTER** button to enter the Route Number.

The display will ask if you wish to reset the customer number.



RESET CUST? [Yes]



Press the **ENTER** button to reset the customer number.



NEXT CUST # 1

4.4 METER SET UP FOR WEIGH-IN-MOTION



Press the **PWR / MENU** button to enter the Program Menu.



Press the **CYCLE** button until **CONFIGURE SYSTEM** is displayed.



CONFIGURE SYSTEM



Press the **ENTER** button to select the **CONFIGURE SYSTEM** Menu option.



Press the **CYCLE** button until **CONF: METHOD** is displayed.



CONF: METHOD



Press the **ENTER** button to select the **CONF: METHOD** Menu option.



METHOD: [MOTION]



OR

Press either the **UP** or **DOWN ARROW** buttons until **METHOD: [MOTION]** is displayed.



Press the **ENTER** button to store the method and return to the **CONF: METHOD** Menu option.

4.5 VERIFY FORK OPERATION

Verify the forks are working by either sitting or standing on the each fork. The scales should read the amount of weight on each fork.

1. Run the lift arms up and down and make sure they are slow and smooth in the weighing range.

If not:

- Check the hydraulic valve setting; it should be 1-3/4 turns open
 - Hydraulic trip point should be about 6 feet off the ground and should be the same spot going up and down.
 - Check to see where the hydraulics engages on the up cycle.
2. Lift a bin (with some weight preferred, but empty will do) through the up and down cycle 5 times without dumping and check the repeatability on the meter's computed answer. Look at each "up" answer and "down" answer the meter computes. All "up" answers should be close together and all "down" answers should be close together, although they may not be equal to the exact pound or kilogram.

If you need additional assistance, parts, or service, give us a call at:

VULCAN CUSTOMER SERVICE

1-800-237-0022

HOURS:

7:30 a.m. - 5:00 p.m.

PACIFIC TIME

