

# ROLL-OFF SCALE SYSTEM

## LOW HINGE

MAXIMUM BOX WEIGHT: 62,000 LBS.

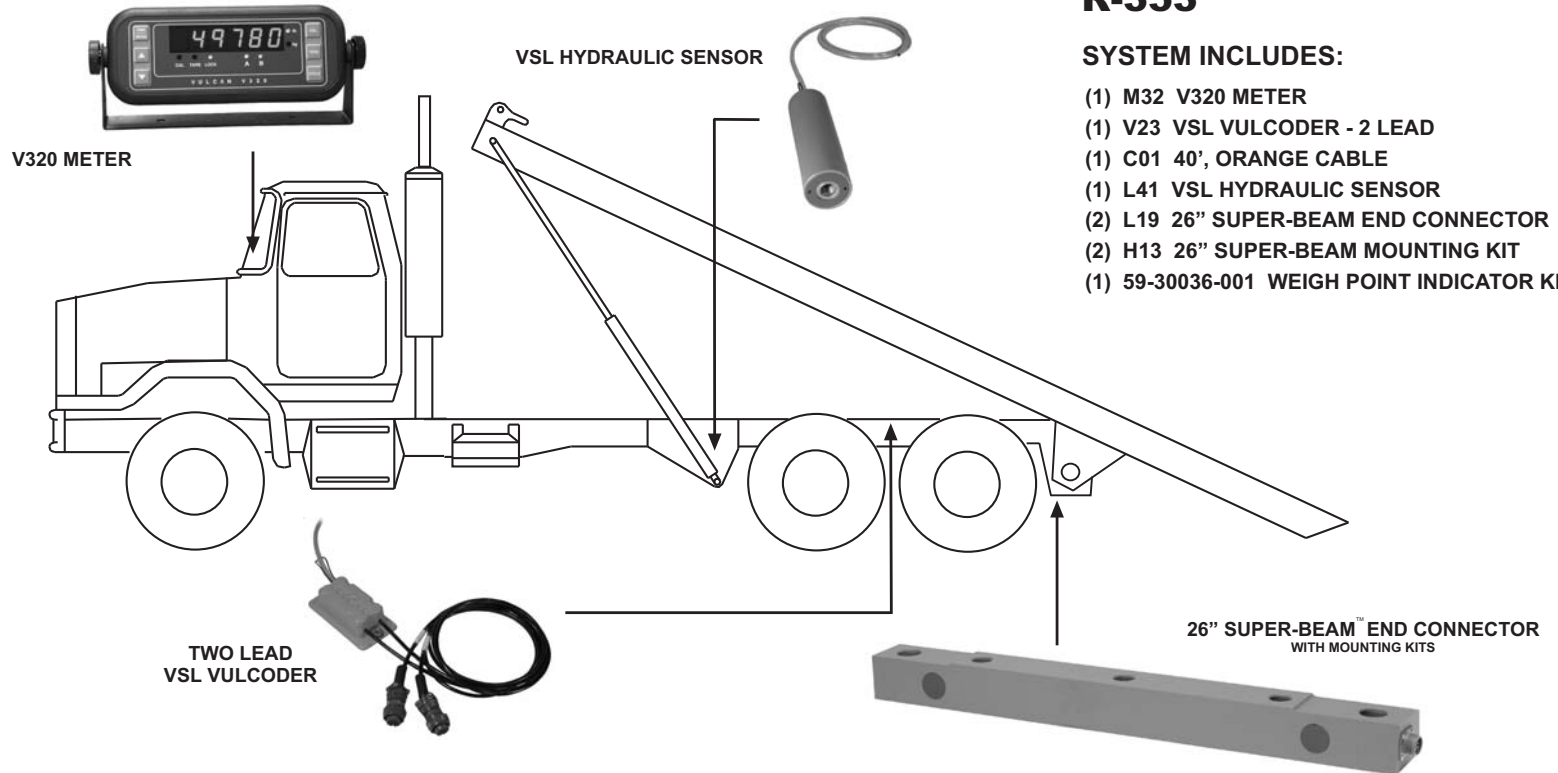

### R-353

#### SYSTEM INCLUDES:

- (1) M32 V320 METER
- (1) V23 VSL VULCODER - 2 LEAD
- (1) C01 40', ORANGE CABLE
- (1) L41 VSL HYDRAULIC SENSOR
- (2) L19 26" SUPER-BEAM END CONNECTOR
- (2) H13 26" SUPER-BEAM MOUNTING KIT
- (1) 59-30036-001 WEIGH POINT INDICATOR KIT



The Vulcan low hinge on-board roll-off scale system uses proven technology to give you the reliability and accuracy you expect. Vulcan 26" Super-Beam load cells with end connectors provide a reliable way to scale roll-offs. An all-digital hydraulic pressure sensor obtains weight by measuring hoist cylinder pressure. Vulcan Super-Beam load cells are mounted underneath the rear hinge assembly to measure weight on the rear hinge. Easy to operate Vulcan electronics provide total weight of the containers and it's contents to the driver in the cab. The system is simple and easy to use.

REPRESENTED BY: