

ROLL-OFF SCALE SYSTEM

2 1/2" DIAMETER REAR HINGE PINS with REAR HINGE MOUNTING KIT

MAXIMUM BOX WEIGHT: 62,000 LBS.

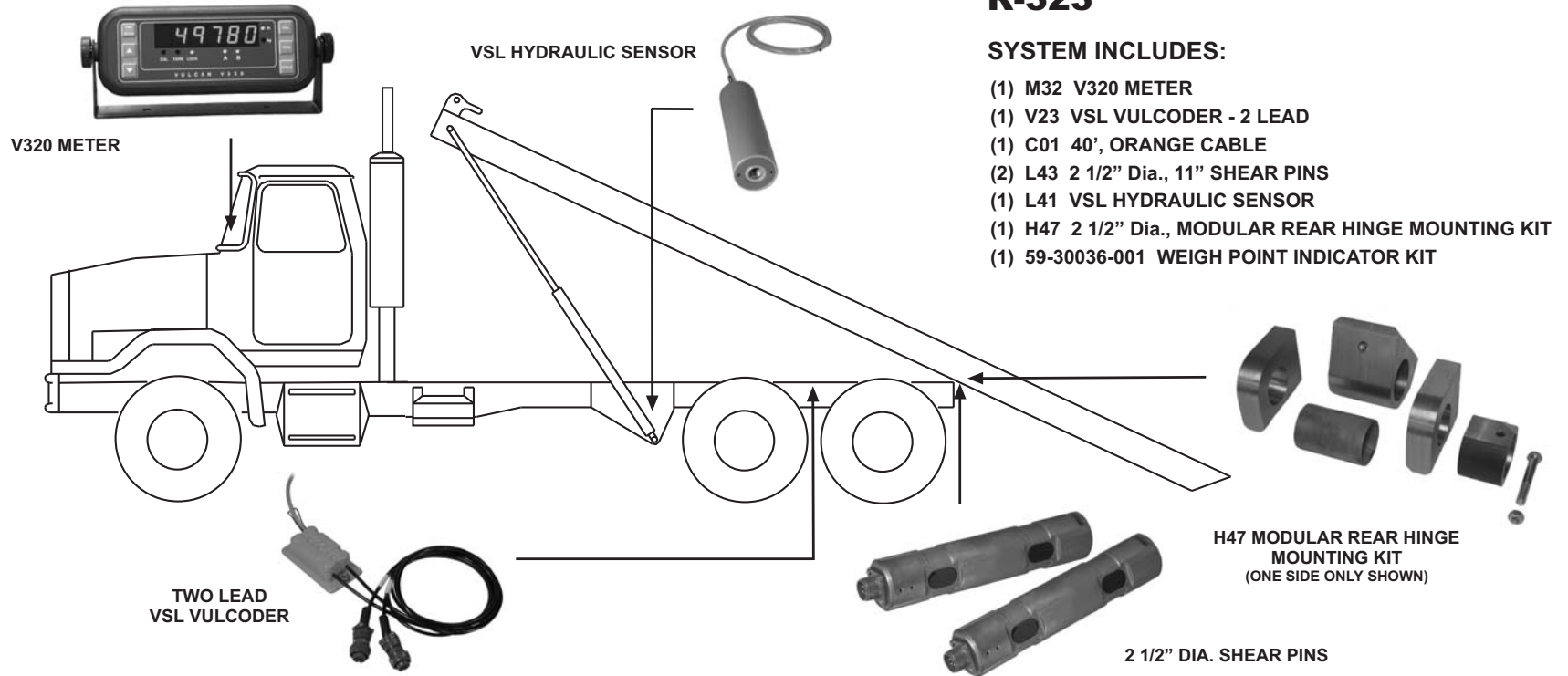

R-323

SYSTEM INCLUDES:

- (1) M32 V320 METER
- (1) V23 VSL VULCODER - 2 LEAD
- (1) C01 40', ORANGE CABLE
- (2) L43 2 1/2" Dia., 11" SHEAR PINS
- (1) L41 VSL HYDRAULIC SENSOR
- (1) H47 2 1/2" Dia., MODULAR REAR HINGE MOUNTING KIT
- (1) 59-30036-001 WEIGH POINT INDICATOR KIT



The Vulcan on-board roll-off scale system with rear hinge mounting kit uses proven technology to give you the reliability and accuracy you expect. A 2 1/2" diameter modular rear hinge mounting kit is provided for roll-off applications where the existing rear hinge assembly can not be used. A hydraulic pressure sensor obtains weight by measuring hoist cylinder pressure. Our durable Vulcan shear pin load cells measure weight at the rear hinge assembly. Easy to operate Vulcan electronics provide total weight of the container and it's contents to the driver in the cab. The system is simple and easy to use.

REPRESENTED BY: