

DUMP TRUCK SCALE SYSTEM

SHEAR PIN SYSTEM

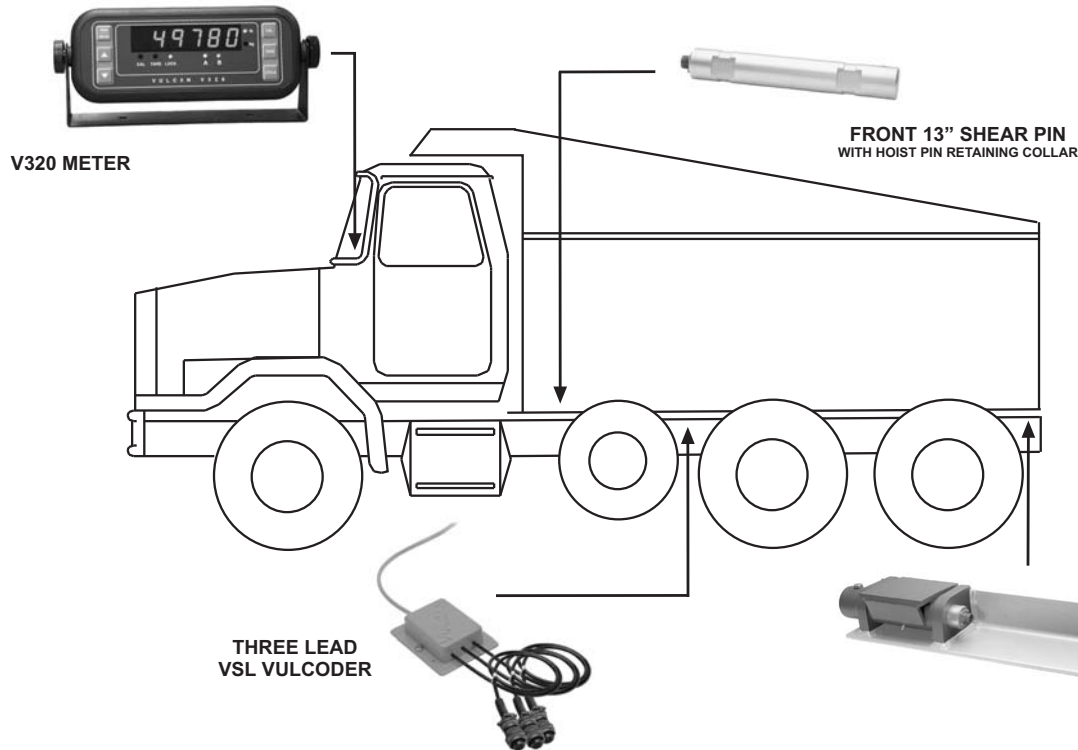

G-503

SYSTEM INCLUDES:

- (1) M32 V320 METER
- (1) V32 VSL VULCODER - 3 LEAD
- (1) C04 ORANGE CABLE, 45' w / RECEPTACLE
- (2) L25 2" Dia., 11 1/2" SHEAR PINS
- (1) L26 13" SHEAR PIN
- (1) H28 REAR HINGE ASSEMBLY
- (1) H29 HOIST PIN RETAINING COLLAR

NOTE: Optional H34 Modular Hinge Kit available to replace full H28 rear hinge assembly



The Vulcan shear pin dump truck scale system operates reliably in harsh environments and is the most accurate method to measure dump truck payload weights. The standard system includes a full rear hinge assembly and bracket to replace the truck's existing hinge and bracket. For this configuration a durable Vulcan shear pin load cell under the hoist cylinder measures front end box weight, and Vulcan shear pin load cells measure weight at the rear hinge assembly. Vulcan electronics provide the operator payload weight information to optimize loading and operation.

REPRESENTED BY: