

SUPER B LOGGER SCALE SYSTEM

V300 ELECTRONICS

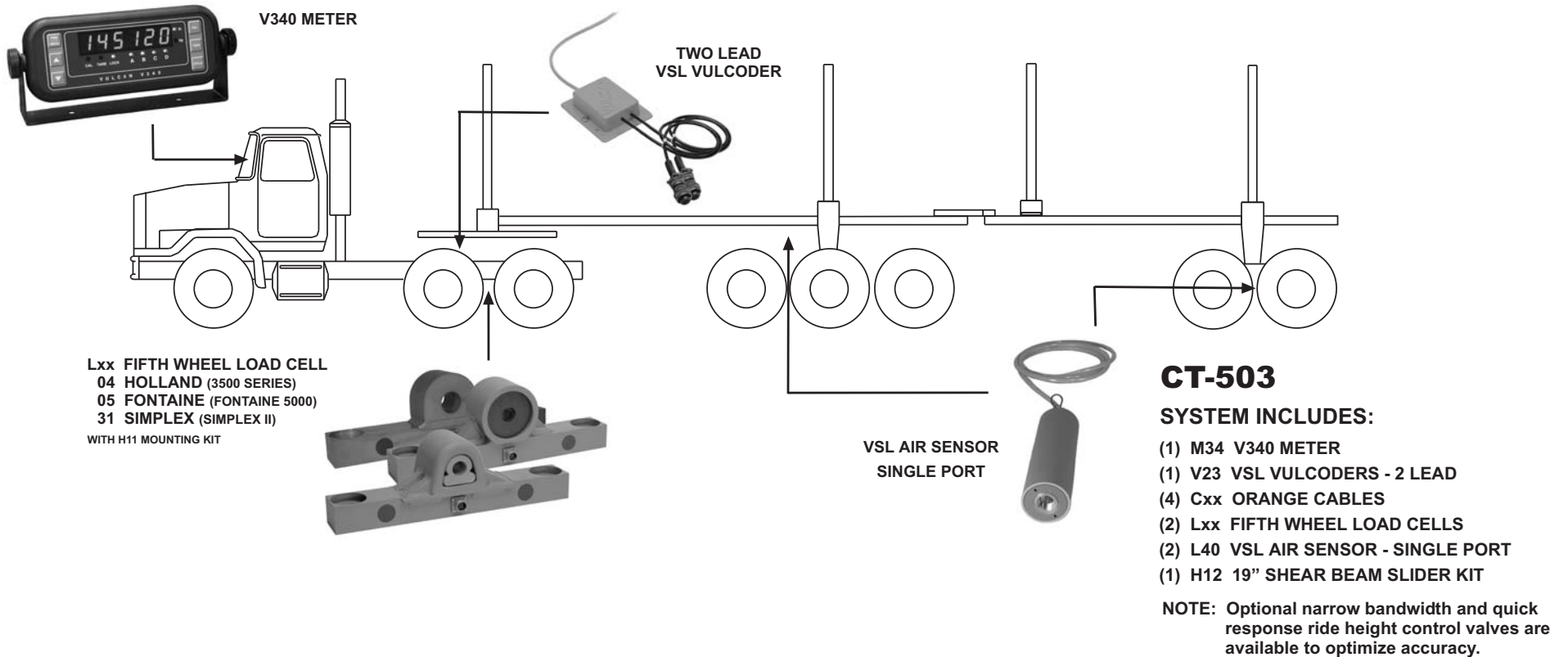

The Vulcan Super "B" logger scale system provides the most accurate and reliable system available for this combination of trailers. Vulcans fifth wheel load cells and rugged, all-digital air sensors work together to meet the unique and harsh requirements of this application. Vulcan air sensors are altitude and temperature compensated to enhance performance and accuracy. The scale system measures individual axle, total gross or net payload weights.

REPRESENTED BY: